

## IMPORTANT:

The product is powered by electricity. In order to avoid burns, fire and electric shock, please read the instructions carefully. Failure to read, thoroughly understand, and follow all instructions can result in serious personal injury, damage to equipment, or voiding of factory warranty. Should you ever have any questions or feel you require help please contact your place of purchase for assistance.

## Instructions of Safety and Warnings

- Make sure that the mounting surface is strong enough to handle mounted product and equipment.
- **DO NOT EXCEED MAXIMUM LISTED WEIGHT CAPACITY.**
- Always be sure to have someone assist you or a mechanical device to lift and position heavy products safely.
- Tighten screws firmly, but do not over tighten. Over tightening can cause product damage that greatly reduces the holding power.
- Keep a clear area and distance from moving parts when using the product.
- Use only as intended. Never stand, hang or climb on the product.
- This product is intended for indoor use only.
- Any attempts to reconstruct the construction or alterations of the given power unit and control box aren't allowed.
- This product may contain small items that could be a choking hazard if swallowed. Keep children away unless the product is intended for their use and all instructions and manuals are fully reviewed and understood by them.
- Check that the product is secure and safe to use at regular intervals (at least every three months).

## Other Cautions



Don't clean the product with water while the power is still connected.



Don't disassemble or replace components while the power is still connected.



Never operate the system with a damaged cord or plug.



Never operate the system if it's in moist environment or its electrical components have contact with liquids.



If the control box makes unusual noise or smells, switch off the mains voltage immediately.



**Disposal:** The product with this mark indicates that this product shouldn't be disposed with other household wastes throughout the EU. To prevent possible harm to the environment or human health from uncontrolled waste disposal, recycle it responsibly to promote the sustainable reuse of material resources. To return your used device, please use the local recycle service or contact your point of purchase to withdraw the product.

The product has been designed to meet Commission Regulation with regard to ecodesign requirements for electric power consumption of Standby Mode condition of electrical and electronic household equipment.

**Mode: Standby Mode Power consumption (Watts): ≤0.5W No power management function**

The product has been plugged into the main and without any function.

After the intended function is finished, hold "M" and "TV" for 5 seconds until you hear the beep. The product will then go to standby mode.

Manufactured in China by Brateck for MOUNTS-IN GROUP MB

[www.mounts-in.lt](http://www.mounts-in.lt) | [www.mounts-in.lv](http://www.mounts-in.lv) | [www.mounts-in.ee](http://www.mounts-in.ee) | [www.mounts-in.com](http://www.mounts-in.com)

MOUNTS-IN

Instruction Manual

# MOTORIZED TV CART

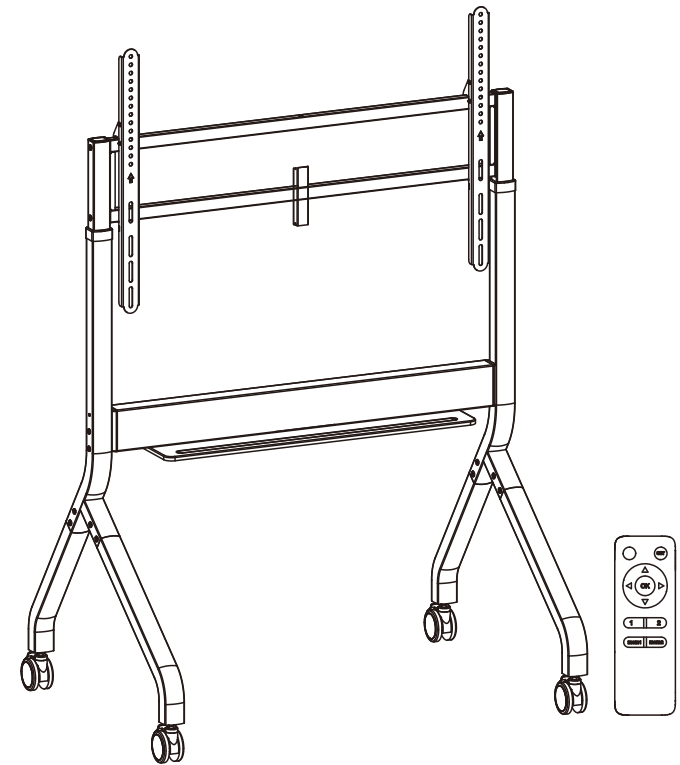

**TTF19S-69FW**

VESA Compatible  
100x100 200x100 200x200 300x200  
400x200 300x300 400x300 600x200  
400x400 600x300 600x400 800x400  
600x600 800x600 900x600

**90"**  
MAX

**90kg**  
(198lbs)  
RATED  
TV

**3kg**  
(6.6lbs)  
RATED  
SHELF

The product is powered by electricity. In order to avoid burns, fire and electric shock and make sure the safe and correct use of the system and maintain the longevity of the overall construction and the built-in electronics, please read the instructions carefully.

### ⚠ Warnings

- This appliance can be used by children aged from 8 years and above if they have been given supervision or instruction concerning use of the appliance in a safe way and understand the hazards involved. Children shall not play with the appliance. Cleaning and user maintenance shall not be made by children without supervision.
- Persons with reduced physical, sensory or mental capabilities or lack of experience and knowledge must not use the appliance, unless they're under supervision, understand the hazards involved or they have been thoroughly instructed in the use of the apparatus by a person who is responsible for the safety of these persons.
- Don't leave the cords or plug unorganized in order to prevent tripping hazards.
- Any attempts to reconstruct the construction aren't allowed.

### ⚠ Electrical Safety Instructions

- The appliance is only to be used with the power supply unit provided with the appliance. Alterations of the given power unit aren't allowed.
- Never operate the system with a damaged power supply cord or plug. If any parts is damaged, please contact your service agent of purchase for a replacement.
- Never operate the system if it's in moist environment or its electrical components has contact with liquids.
- Don't clean the product while the power is still connected.
- Don't disassemble or replace components while the power is still connected.
- Unplug the appliance when the system isn't in use, and place the power plug out of children reach.

## Pairing the Remote to the Mount & Resetting the System

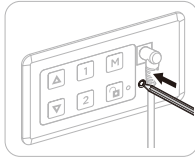

**STEP 1: If it is the first time you turn on the mount, you should pair the remote to the mount first then reset the system. See the STEP 2 below.**

**STEP 2:** Press the small button on the control panel with a paper clip or pencil as shown. After you hearing a beep, press the "⏻" button on the remote control, then you hear consecutive beeps for around 10 seconds indicating the pairing is ongoing. After that, the unit beeps once again, and stop, meaning the pairing is completed. And then reset the system via remote or control panel as following instructions.

### Remote Control User Guide

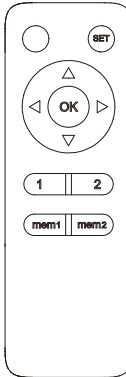

#### 1. UP/DOWN ARROWS

Press and hold the "▲" button to raise the Mount. Press and hold the "▼" button to lower the Mount.

**Note:** Remove all surrounding items prior to adjusting the Mount height.

#### 2. Memory Setting

Long press the "mem1" or "mem2" button for 3 seconds until you hear a beep, indicating that the current position has been saved to memory. The "mem1" or "mem2" buttons can each store a height.

#### 3. Activate Height Settings

Press the "1" or "2" button and the mount will automatically get to the position saved in the corresponding button "mem1" or "mem2", and press OK to stop.

#### 4. Reset Mode

Long press the "⏻" button for 3 seconds until you hear a beep, and the mount starts to move downwards. Then the mount will move upwards a little bit when reaching the lowest position and stop. The system resets successfully when the unit beeps twice.

#### 5. To Unpair a Remote Control

Press the small button on the control panel with a paper clip or pencil as how you pairing the remote control. After hearing a beep, hold and press the button until you hear a long beep, which indicates the unpairing is completed.

**Note:** To disable the remote control function, hold the "M" and "⏻" of the control panel on back of the crossbar for 5 seconds until you hear the beep. Press the "⏻" on the panel to restart the remote control function.

### Control Panel User Guide

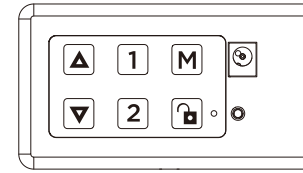

#### 1. UP/DOWN ARROWS

Press and hold the "▲" button to raise the Mount. Press and hold the "▼" button to lower the Mount.

**Note:** Remove all surrounding items prior to adjusting the Mount height.

#### 2. Memory Setting

Long press the "1" or "2" button for 3 seconds until you hear a beep, indicating that the current position has been saved to memory.

The "1" "2" buttons can each store a height.

#### 3. Activate Height Settings

Press the "1" or "2" button and the mount will automatically get to the position saved in the corresponding button "1" or "2", and press any button to stop.

#### 4. Reset Mode

Long press the "M" button for 5 seconds until you hear a beep, and the mount starts to move downwards. Then the mount will move upwards a little bit when reaching the lowest position and stop. The system resets successfully when the unit beeps twice.

### Child Lock Function

#### 1. Auto Lock Function Setting

By default, this function is disabled. To enable it, press the < on the remote control or press the ⏻ on the control panel 5 times. A single beep indicates that the auto-lock function is activated, while two beeps indicate deactivation.

#### 2. Auto Lock

When the auto-lock function is enabled, the device will automatically lock if it is not operated for 60 seconds. The panel indicator light will turn on, and all buttons will be unresponsive. To unlock, press and hold the < on the remote control or the ⏻ on the control panel for 3 seconds. A single beep indicates unlock, and the panel indicator light will turn off.

#### 3. Manual Lock

When the auto-lock function is disabled, users can manually lock and unlock the device. Press and hold the < on the remote control or the ⏻ on the control panel button for 3 seconds. Two beeps indicate the device is locked, and the panel indicator light will turn on. A single beep indicates unlock, and the panel indicator light will turn off.

## Troubleshooting Guide

### 1. Can't operate

#### There are 10 possibilities:

- If the unit beeps once after pressing the up, down or memory buttons, check to see if the mount has reached its maximum height, minimum height or a designated position. If so, follow the instructions in the manual to properly operate the mount.
- If the stand hits an obstacle while moving up or down, the unit will beep twice and the mount will stop after rebounding a short distance.
- The system of Mount may be error. Check if the unit beeps three times after pressing a button. If so, please reset the mount or turn off the power, check the wiring, and then restart the system.
- The system may be overheating. Check if the unit beeps four times after pressing a button. If so, allow the unit to cool down (about 18-30 minutes).
- If the up or down movement stops suddenly and the unit beeps five times, this indicates a power problem.
- If the up or down movement stops suddenly and the unit beeps six times, this indicates that the mount is overloaded.
- The AC/DC end of the power cord may be unplugged/disconnect from the outlet/mount. Check the connection to ensure the unit is powered.
- The operating distance may be too far and not in range of the mount. Using the remote control within 30 feet (10m) from the Mount.
- The batteries in the remote control may be low or dead. Replace the batteries.
- The remote control may be broken. Check to see if the indicator LED found on the remote lights when a button is pressed. If not, contact your place of purchase for a replacement.

### 2. The TV mount is making an abnormal noise or sound.

- Check all power connections and reset the system. If the unit continues to make an abnormal noise, please contact your place of purchase for a replacement.

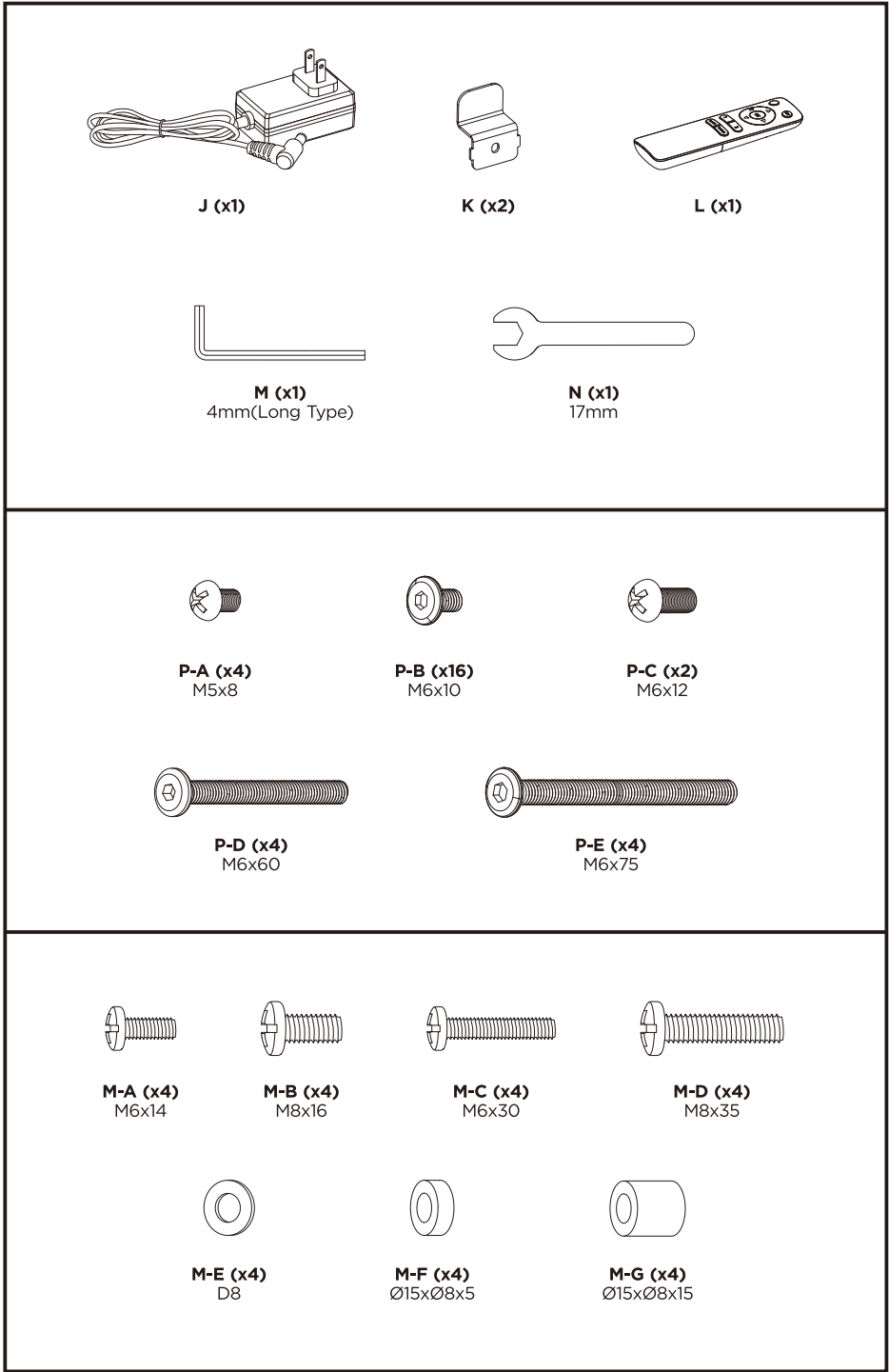
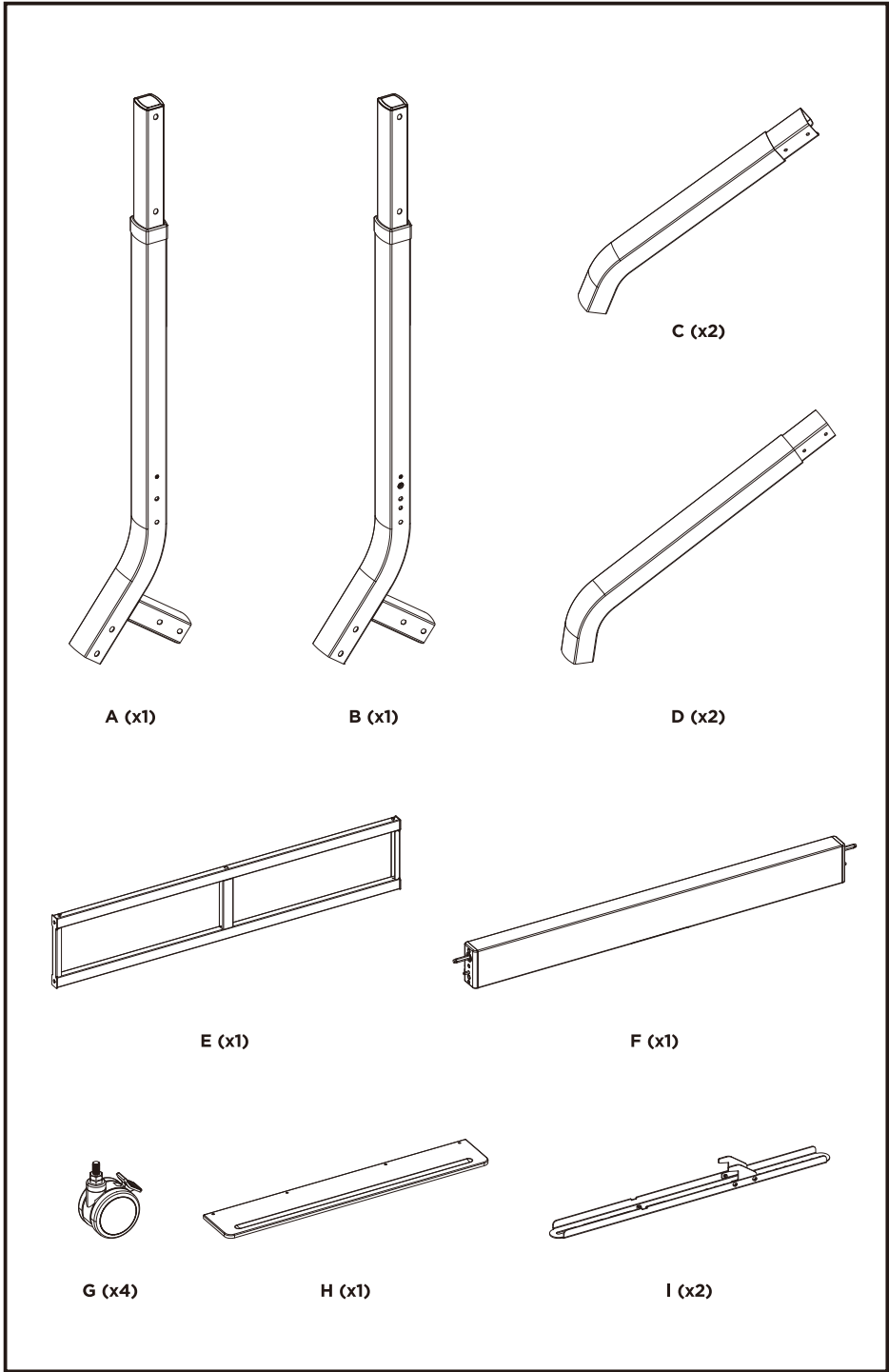

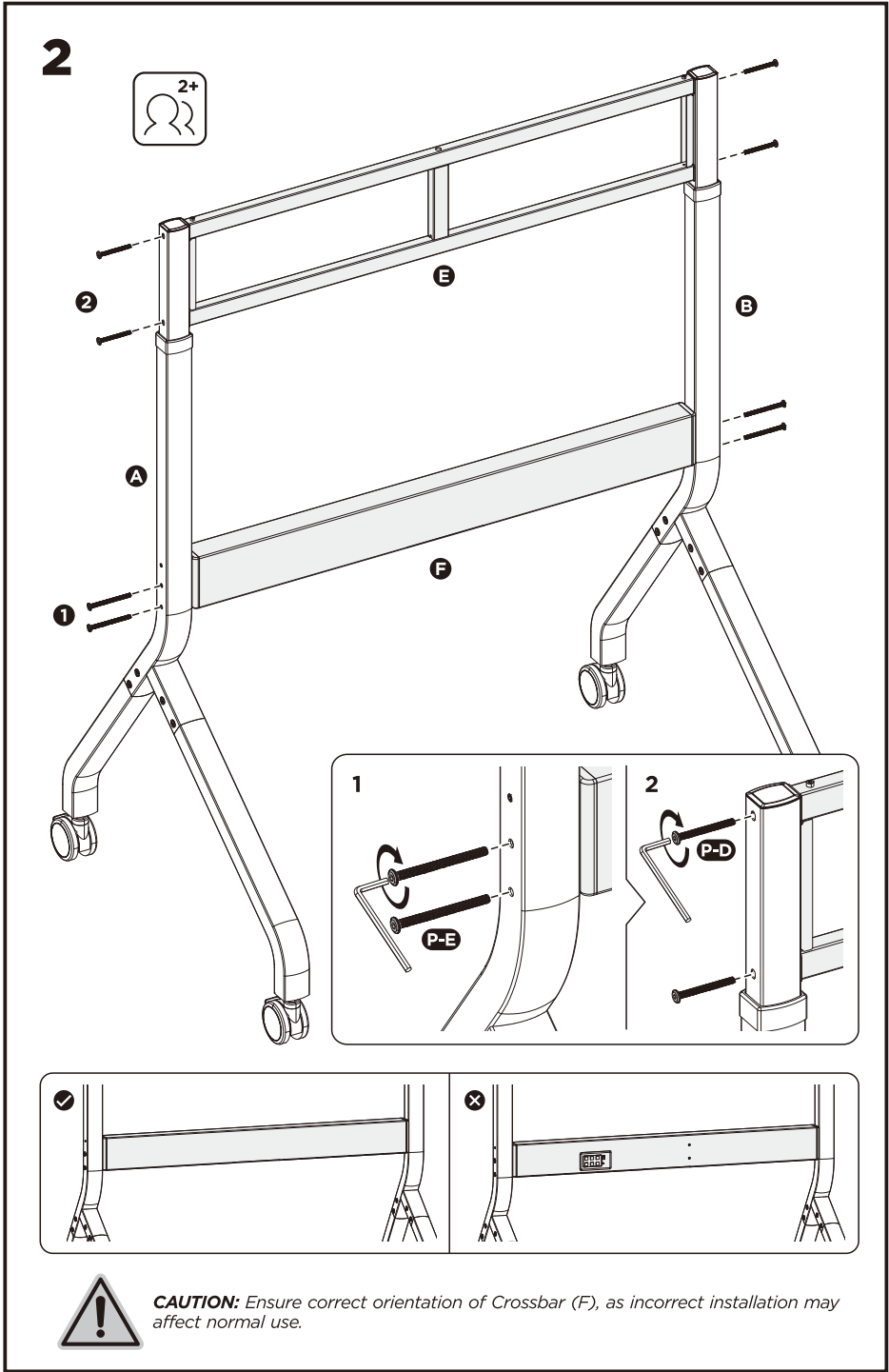
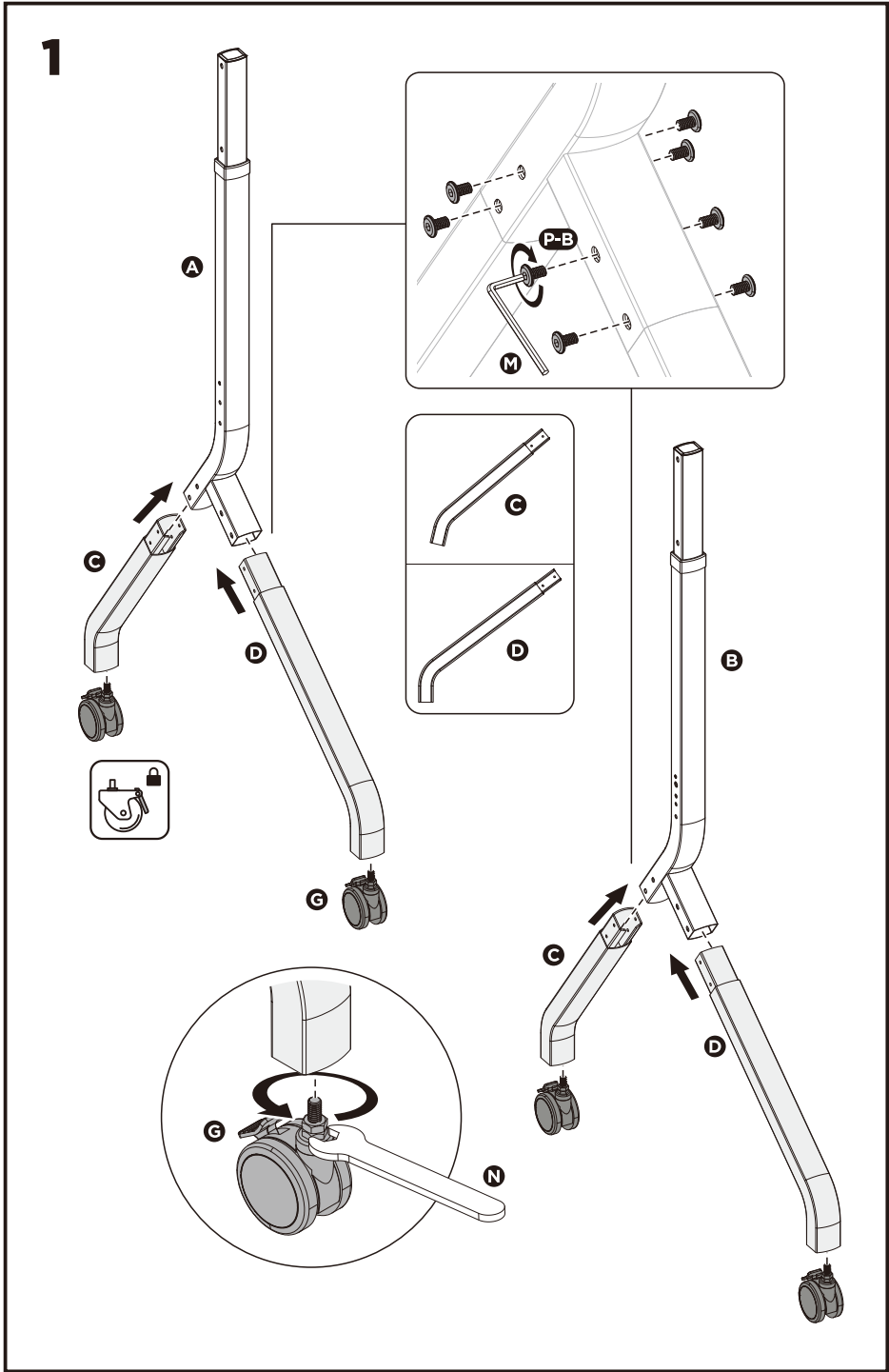

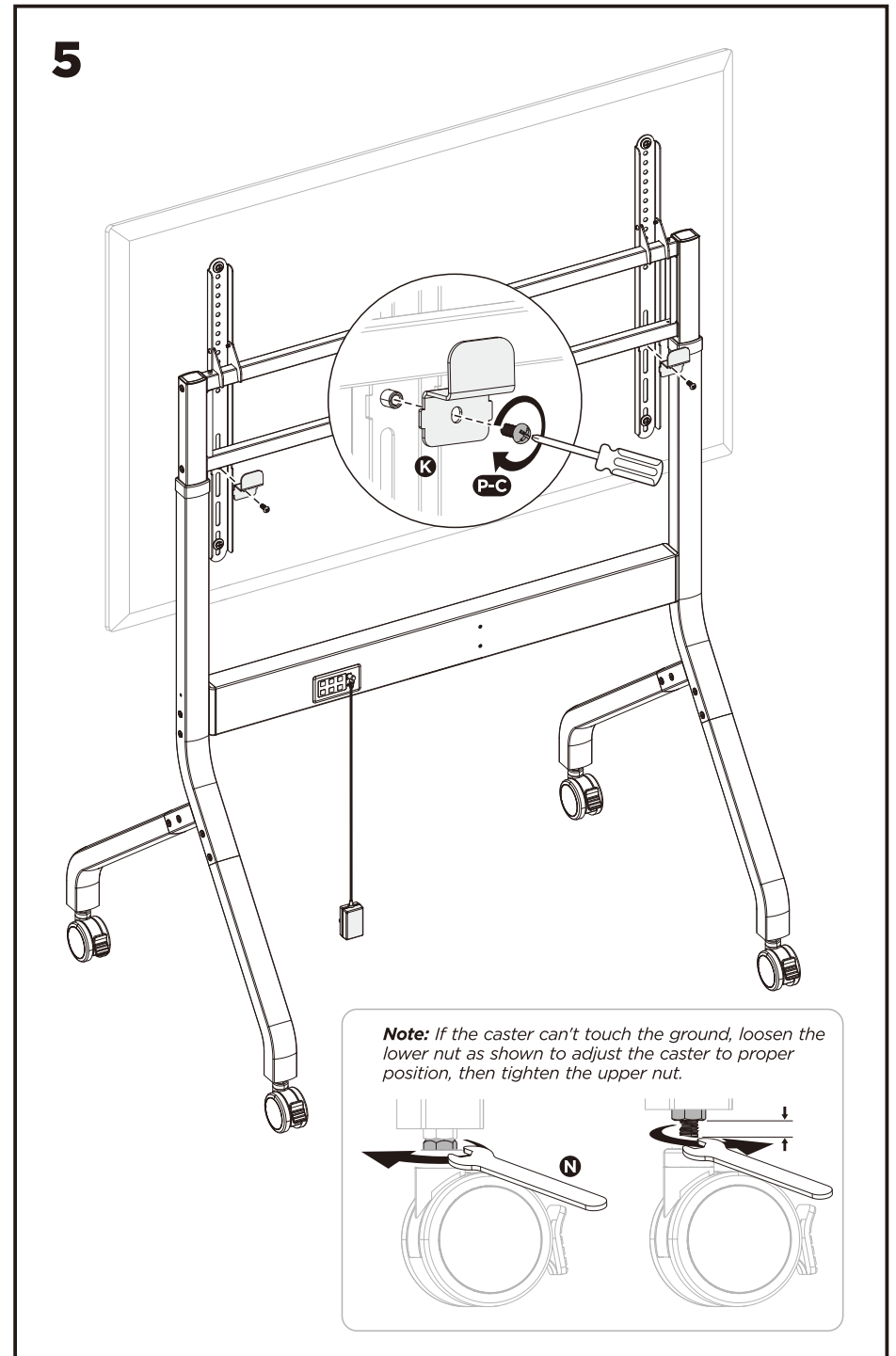
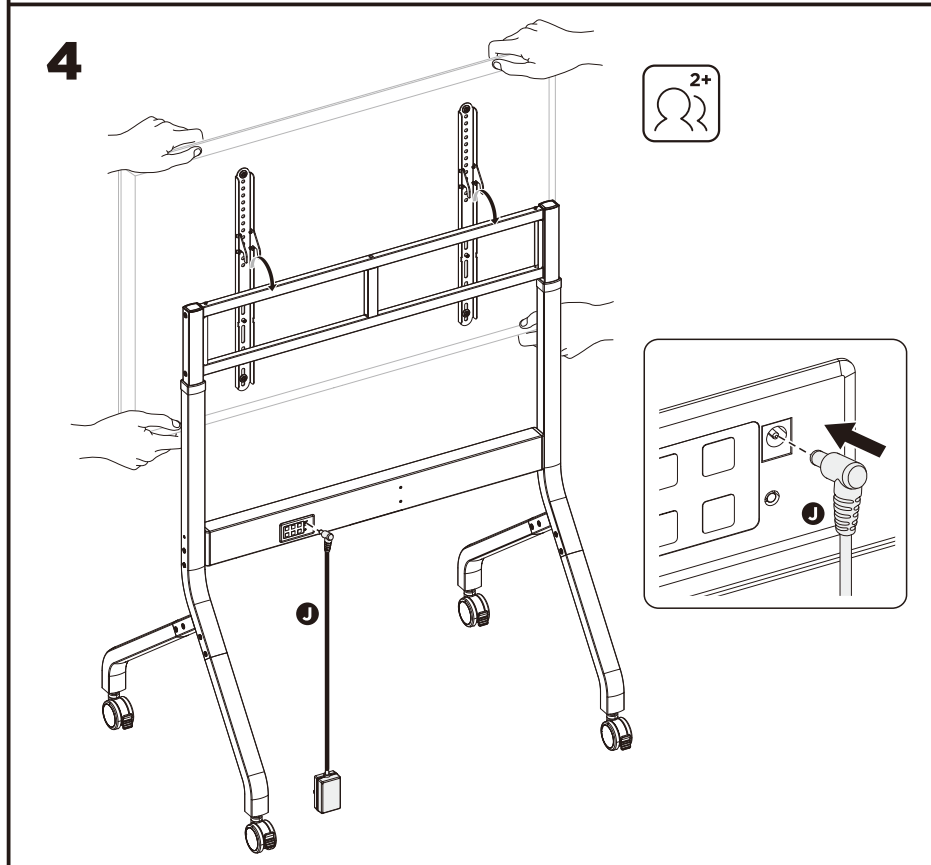
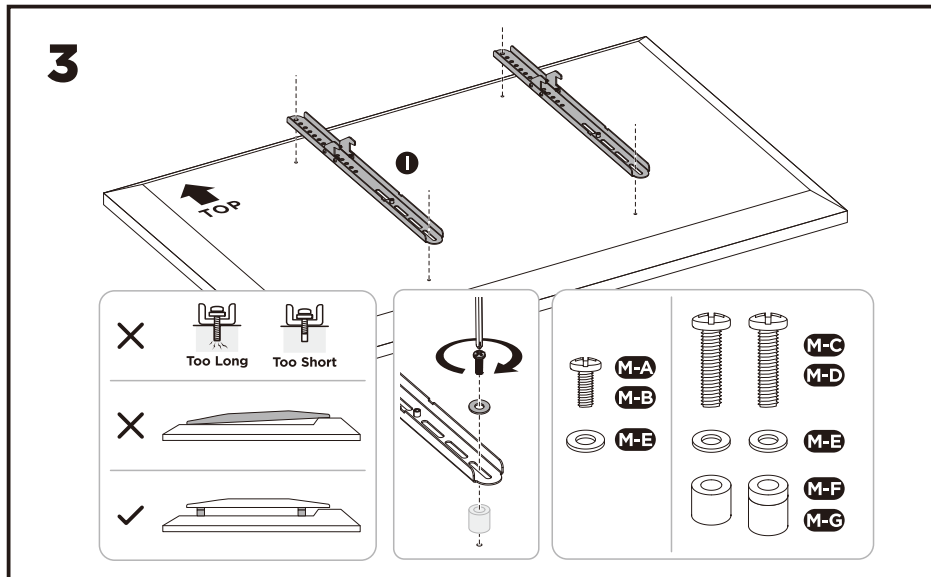

6

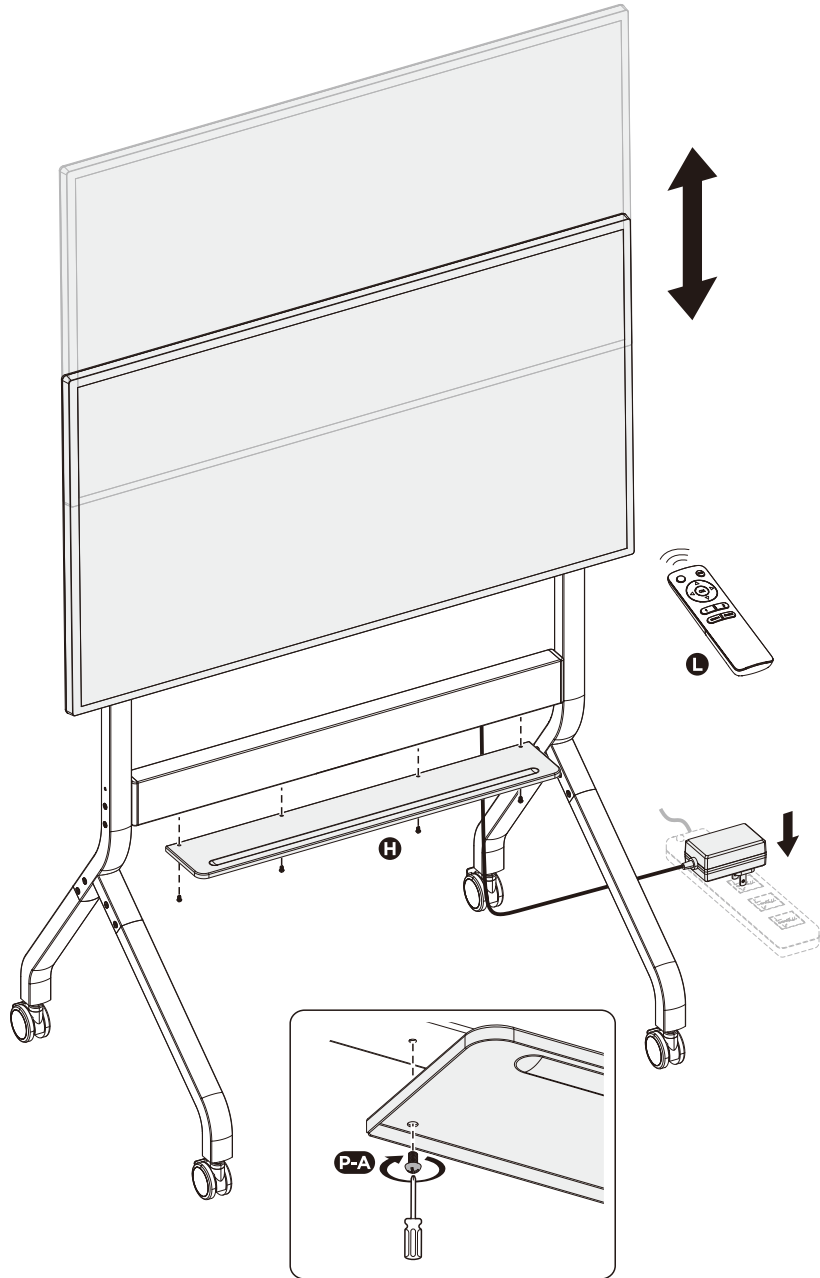

**Note:** If the TV interferes with the shelf, the shelf installation can be omitted.